

NEXGRILL

Oakford 580
Pellet Grill
Model: 910-05001AU

OAKFORD

PELLET  GRILLS



Owner's Guide

**IMPORTANT INFORMATION.
MUST READ BEFORE
OPERATING. KEEP FOR FUTURE
REFERENCE.**

**A MAJOR CAUSE OF FIRES IS FAILURE TO MAINTAIN
REQUIRED CLEARANCES (AIR SPACES) TO
COMBUSTIBLE MATERIALS. IT IS OF UTMOST
IMPORTANCE THAT THIS PRODUCT BE INSTALLED
ONLY IN ACCORDANCE WITH THESE INSTRUCTIONS.**

DO NOT USE INDOORS!
Not for commercial use.

910-05001AU-062223

TABLE OF CONTENTS / TABLE DES MATIÈRES / ÍNDICE /
 INDHOLDSFORTEGNELSE / INHALTSVERZEICHNIS

EN	Important Safety Information	3	Turning Off Your Grill	17
	Pellet Grill System	5	Lighting Your Grill -	18
	Package Parts	6	Manually	18
	List	6	Changing	18
	Assembly Instructions	8	Pellets	18
	Controller	16	Using Temperature Probes	18
	Guide	16	Care and Maintenance	19
	Operating Instructions	17	Instructions	19
	Before First	17	Troubleshooting	20
	Use	17	Electrical Circuit	21
Each and Every	17	Diagram	21	
		Limited Warranty	22	

PLEASE READ THIS ENTIRE MANUAL BEFORE INSTALLATION AND USE OF THIS PELLET FUEL-BURNING APPLIANCE. FAILURE TO FOLLOW THESE INSTRUCTIONS COULD RESULT IN PROPERTY DAMAGE, BODILY INJURY OR EVEN DEATH. SAVE THESE INSTRUCTIONS.

CONTACT LOCAL BUILDING OR FIRE OFFICIALS ABOUT RESTRICTIONS AND INSTALLATION INSPECTION REQUIREMENTS IN YOUR AREA.

Important SAFETY INFORMATION

WARNING! Follow these guidelines to prevent this colorless, odorless gas from poisoning you, your family or others:

- Know the symptoms of carbon monoxide poisoning: headache, dizziness, weakness, nausea, vomiting, sleepiness, and confusion. Carbon monoxide reduces the blood's ability to carry oxygen. Low blood oxygen levels can result in loss of consciousness and death.
- See a doctor if you and others develop cold or flu-like symptoms while cooking or in the vicinity of this appliance. Carbon monoxide poisoning, which can easily be mistaken for cold or flu, is often detected too late.
- Alcohol consumption and drug use increase the effects of carbon monoxide poisoning.

Carbon monoxide is especially toxic to mother and child during pregnancy, infants, the elderly, smokers and people with blood or circulatory system problems, such as anemia or heart disease.



Questions, problems, missing parts?

Before returning to your retailer, call our customer service department at (03) 9702 8823, 8 a.m.-5 p.m., Monday-Friday. SERVICE@HARK.COM.AU

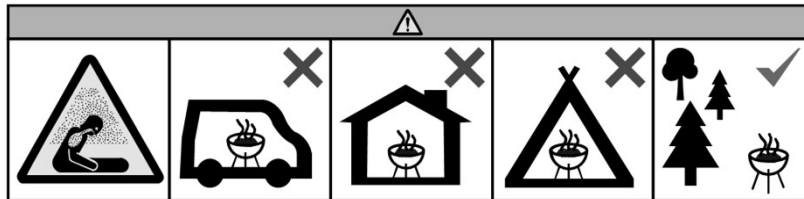

WARNING! Do not use the barbecue in a confined and/or habitable space e.g. houses, tents, caravans, motor homes, boats. Danger of carbon monoxide poisoning fatality.

WARNING! If fire occurs:

- Keep away from the appliance and immediately call your local fire department.
- Do not try to move appliance, smother fire, or put water on the fire
- Keep the appliance clean – refer to the Care and Maintenance Instructions.

CAUTION! Never use gasoline, gasoline-type lantern fuel, kerosene, charcoal lighter fluid, or similar liquids to start or 'freshen up' a fire in this appliance. Keep all such liquids well away from the appliance when in use.

WARNING! This barbecue will become very hot, do not move it during operation.

- Do not use heating grade pellets. Use only cooking grade pellets manufactured of 100% natural wood that is intended for pellet grill usage.
- We recommended using pellets with the following specifications: 8,000-8,500 BTU/LB with ash content less than 1%.
- Do not use pellet fuel labeled as having additives.
- Never put wood chips or chunks into the hopper.
- Only use dry pellets. If the grill was stored with the hopper full, check the pellets to ensure that they are completely dry before use. Hardwood pellets can absorb moisture in wet or humid environments, causing them to expand and possibly obstruct or jam the auger system.
- Never allow the hopper to empty while the grill is in operation. Make sure to fill the pellet hopper with enough pellets before use or refill the pellet hopper as necessary.

SAFETY PRACTICES TO AVOID INJURY

When properly cared for, your grill will provide safe and reliable service for many years. However, extreme care must be used as the grill produces intense heat that has a potential to cause injury when misused. When using this appliance, basic safety practices must be followed, including the following:

- Do not repair or replace any part of the grill unless specifically recommended in this manual. All other service should be referred to a qualified technician.
- This outdoor cooking appliance is not intended to be installed in or on boats and other recreational vehicles.

SAFETY PRACTICES TO AVOID INJURY

- Do not use this grill under any overhead combustible construction including ceilings or overhangs.
- **WARNING!** Keep children and pets away. Children should not be left alone or unattended in an area where the grill is being used. Do not allow them to sit, stand or play in or around the grill at any time.
- This appliance can be used by children aged from 8 years and above and persons with reduced physical, sensory or mental capabilities or lack of experience and knowledge if they have been given supervision or instruction concerning use of the appliance in a safe way and understand the hazards involved. Children shall not play with the appliance. Cleaning and user maintenance shall not be made by children without supervision.
- If the supply cord is damaged, it must be replaced by a special cord or assembly available from the manufacturer or its service agent.
- Do not store items of interest to children around or below the grill.
- For personal safety, wear proper apparel. Loose fitting garments or sleeves should never be worn while using this appliance. Some synthetic fabrics are highly flammable and **should not** be worn while cooking.
- Always use heat-resistant gloves or mitts when handling particularly hot components.
- When using the grill, do not touch the warming rack, burner grate or immediate surroundings as these areas become extremely hot and could cause burns. Use only dry potholders. Moist or damp potholders on hot surfaces may cause steam burns. Do not use a towel or bulky cloth in place or potholders. Do not allow potholders to touch hot portions of the grill rack.
- Only certain types of glass, heat-proof glass ceramic, earthenware, or other glazed utensils are suitable for grill use. These materials may break with sudden temperature changes. Use only on low or medium heat settings in accordance with the manufacturer's guidelines.
- Do not heat unopened food containers. A build-up of pressure may cause the containers to burst.
- Never lean over an open grill.
- Grease is flammable. Let hot grease cool before attempting to handle it. Clean out the grease tray and grease bucket often to avoid build-up.

CAUTION: ELECTRICAL COMPONENTS



- Disconnect the electric power before servicing. Do not attempt to clean or repair the grill while it is connected to an electricity source.
- The external electrical power source used for this appliance must be electrically grounded in accordance with local codes.
- Check the plug receptable before use. Do not plug in the grill if it is damaged.
- Do not use water to control flare ups or extinguish the fire. Turn off the grill, unplug the power cord, and wait for the grill to cool down.
- Always have the grease system properly installed while operating this grill. Never operate without a grease bucket in place under the side shelf.
- Dispose of ashes after the grill has completely cooled following a proper shutdown. Wait until grease and ash are completely cooled before disposing.
- Wait until the fuel is extinguished and the grill is completely cool before moving, covering, or storing the grill.
- Do not use aluminum foil to line the grill racks or grill bottom. This can severely upset combustion air flow or trap excessive heat in the control area.
- Clean the grill with caution. To avoid steam burns, do not use a wet sponge or cloth to clean the grill while it is hot. Some cleaners produce toxic fumes or can ignite if applied to a hot surface.
- Turn off grill controls and make certain the grill is cool before using any type of aerosol cleaner on or around the grill. The chemical that produces the spraying action could, in the presence of heat, ignite or cause metal parts to corrode.
- Keep the area surrounding the grill free from combustible materials including, fluids, trash, and vapors such as gasoline or charcoal lighter fluid. Do not obstruct the flow of combustion and ventilation air.
- To reduce the risk of fire, remove pots and pans while the operating appliance is unattended.
- Do not use accessories that are not specified for this appliance.
- The use of alcohol, prescription, or non-prescription drugs may impair the consumer's ability to properly assemble or safely operate the appliance.
- Disposal of ashes – Ashes should be placed in a metal container with a tight-fitting lid. The closed container of ashes should be placed on a non-combustible floor or on the ground, well away from all combustible materials, pending final disposal. When the ashes are disposed by burial in soil or otherwise locally dispersed, they should be retained in the closed container until all cinders have thoroughly cooled.
- Make sure that the power cord does not come in contact with any hot surfaces.
- Do not cut or remove the grounding prong from the plug. Only use a GFCI protected circuit to power the grill.
- High voltage used to power the grill can cause electric shock, or even death. Do not immerse any electronic or heating element in liquid. Do not use near any source of water or in the rain.
- When unplugging the grill, never pull from the cord. Always pull from the plug itself.



CAUTION:

Do not install or use grill within 24 in (60.96 cm) of combustible materials from back and sides of grill. Grill shall not be located under overhead surfaces (closed carport, garage, porch, patio) that can catch fire.

Pellet GRILL SYSTEM

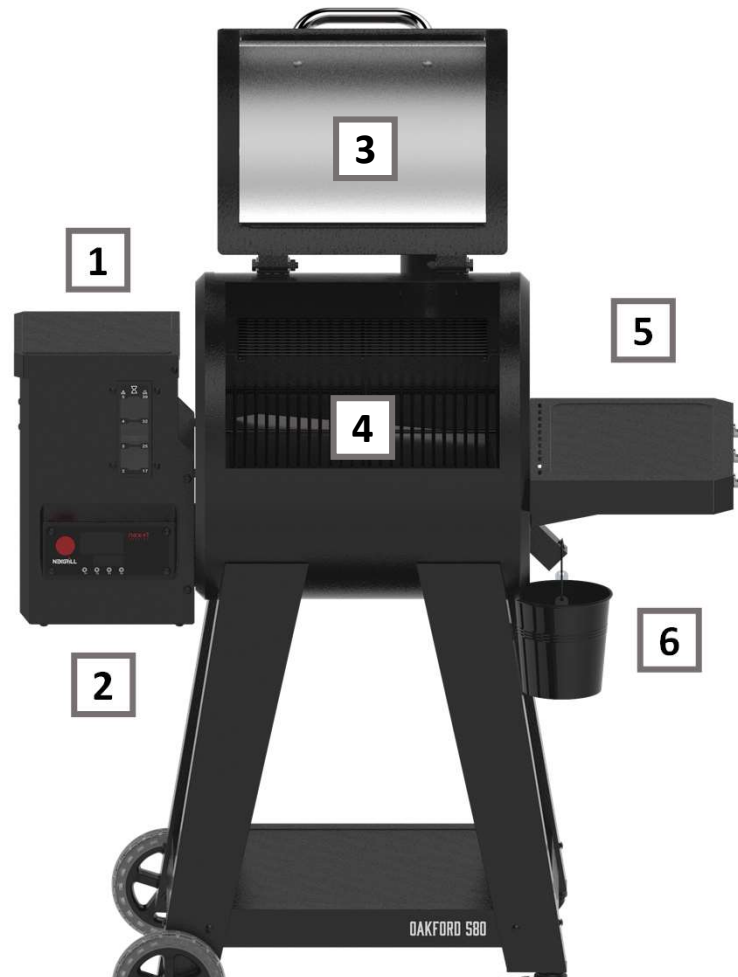

1 Hopper

The large capacity hopper is equipped with rear-access pellet cleanout and can hold enough pellets for an all-day smoking session. The I-Site™ pellet fuel indicator shows the estimated hours of fuel remaining in the hopper, depending on your cooking mode.

4 LARGE COOKING AREA

The porcelain-coated, easy clean, cooking grates will hold plenty of food for all your guests. The top warming rack can be removed to accommodate larger pieces of meat.

2 DIGITAL CONTROLLER

The Wi-Fi and Bluetooth® † enabled SureTemp™ controller with built-in precise temperature control technology can be used to set and adjust the temperature, timer, and cooking options. For the full Oakford™ experience, connect to the NEX-Fi app. See "Connecting to Wi-Fi Network and Bluetooth® †" section for instructions.

5 PREP SPACE

The front and/or side shelves provide ample prep space to hold all your food; with room left over for cooking utensils, seasoning spices, or a cold beverage. Three hooks are located on the side shelf for hanging your grilling tools or mittens. For models that include a front shelf, it can be easily closed by pulling it up and then folding down.

3 LID AND FIREBOX

The high temperature resistance coating helps prevent rusting and cracking over time, keeping your grill looking better for longer. The gasket around the lid helps trap the smoke, delivering a more smoky flavor for your culinary experience.

6 GREASE SYSTEM

Any grease that drips onto the grease tray channels into the bucket. We recommend using aluminum liners for the grease bucket for quick and easy clean up.

† Bluetooth® is a registered trademark of The Bluetooth Special Interest Group (SIG).

Package Parts List

1

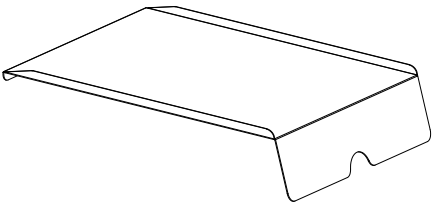

2

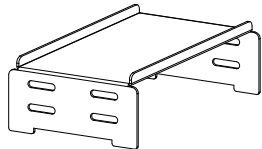

3

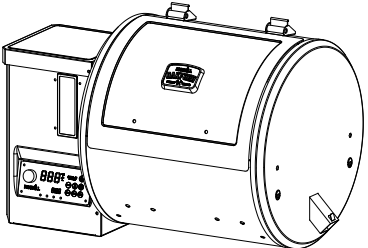

4

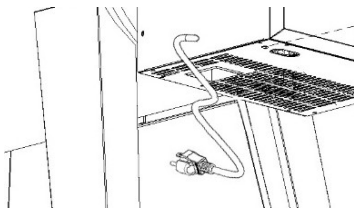

Cord attached

5 x2

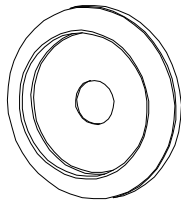

6



7

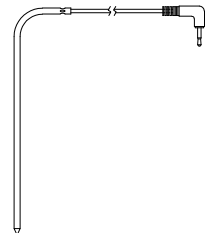

8



9

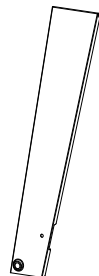

10 x2

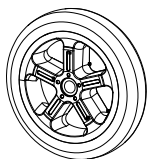

Package Parts List

11 x2

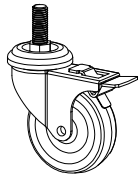

12

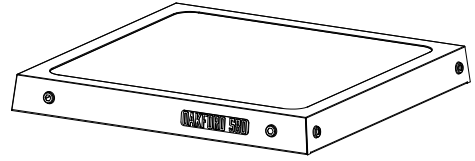

13



14

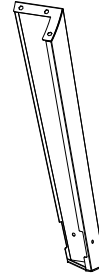

15



16

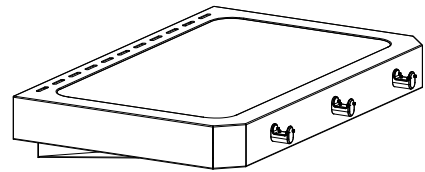

17

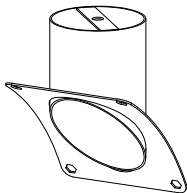

18

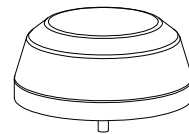

19 x2

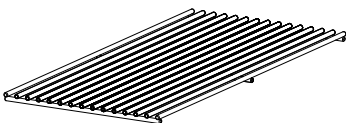

20

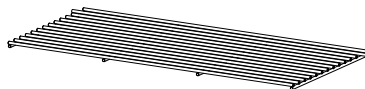

21 x2

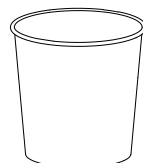

Assembly Instructions



PREPARATION:

Before beginning assembly, installation or operating the product, make sure all parts are present and undamaged. Compare parts with packaging contents list and diagram above. If any part is missing or damaged, do not attempt to assemble, install or operate the product. Contact our customer service for replacement parts.

READ ALL SAFETY WARNINGS, ASSEMBLY AND INSTALLATION INSTRUCTIONS CAREFULLY BEFORE ATTEMPTING TO ASSEMBLE.

Hardware

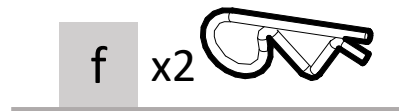
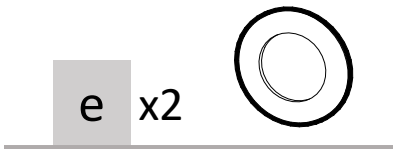
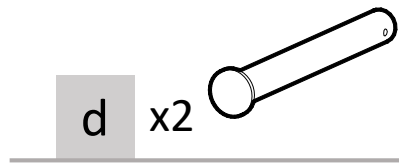

Tools needed (NOT INCLUDED)

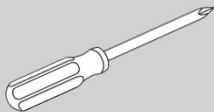

Phillips Screwdriver

SOME PARTS COME WITH SCREWS PRE-INSTALLED. LOOSEN AND TIGHTEN FOR FINAL ASSEMBLY.

TIPS:

- Some assembly steps will require 2 people.
- Use a flat and level surface to assemble the grill.



CAUTION!

Incomplete or improper assembly may be dangerous. Do not use the grill if any parts are missing. The grill must be assembled properly according to the instructions provided by the manufacturer.

1

A×6 B×6 C×6

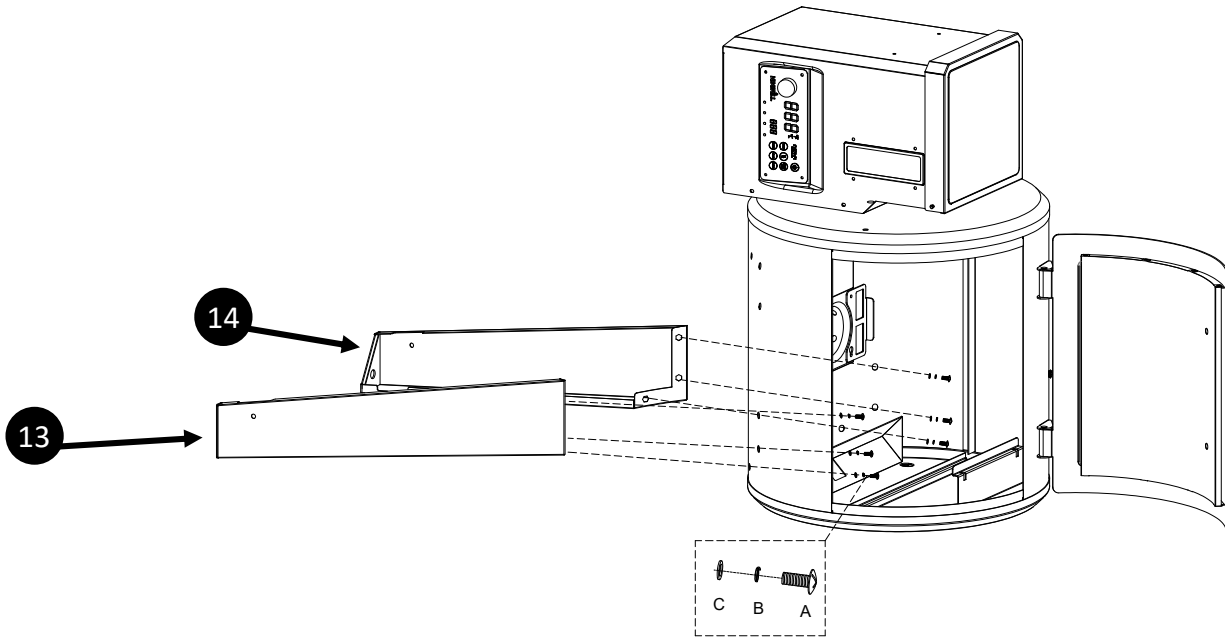

2

A×4 B×4 C×4

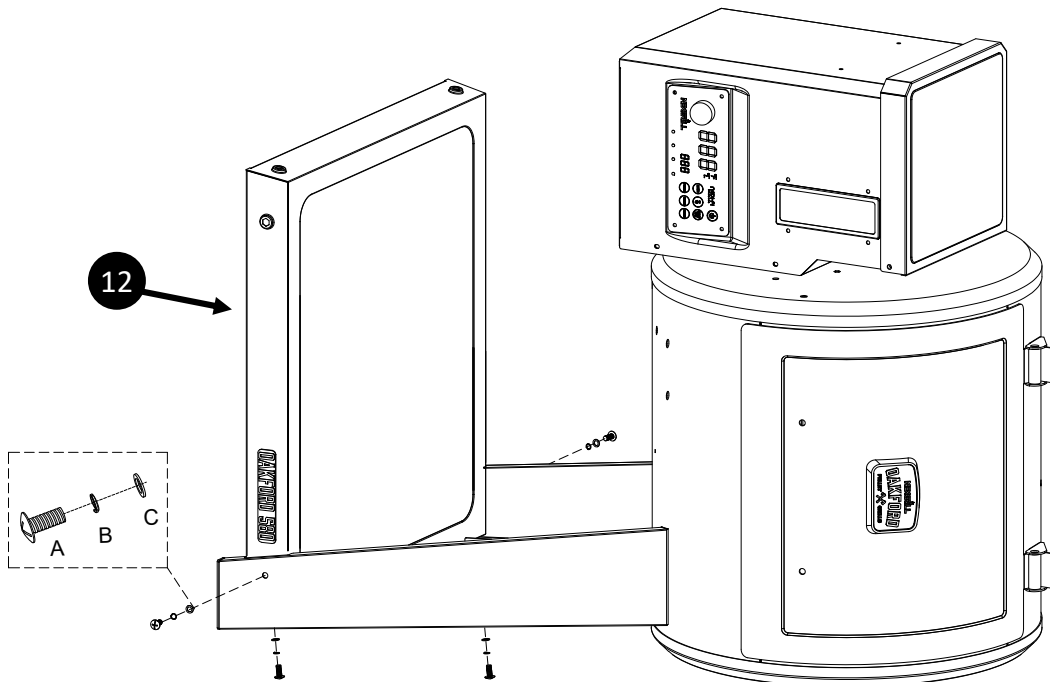

3

A×6 B×6 C×6

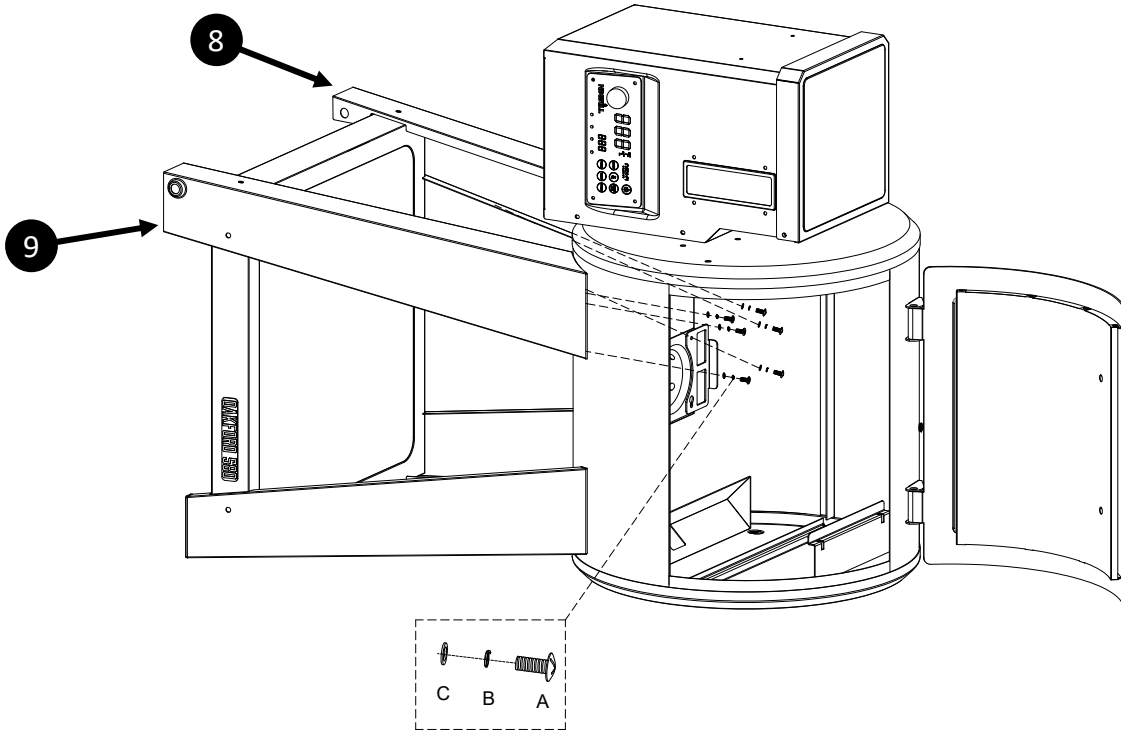

4

A×4 B×4 C×4

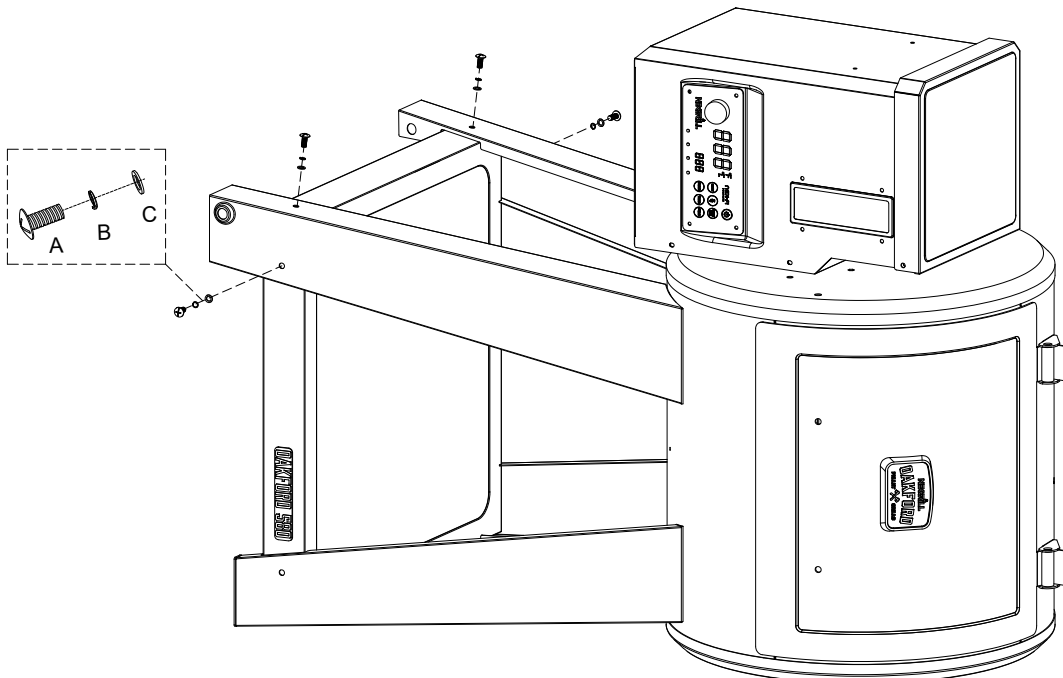

5

D×2 E×2 F×2

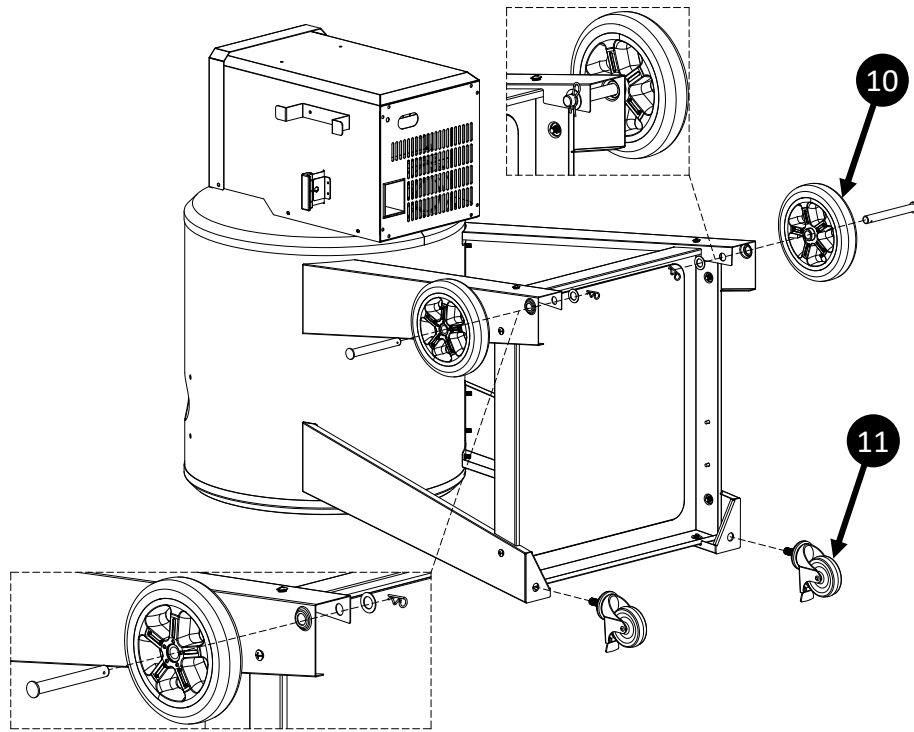

6

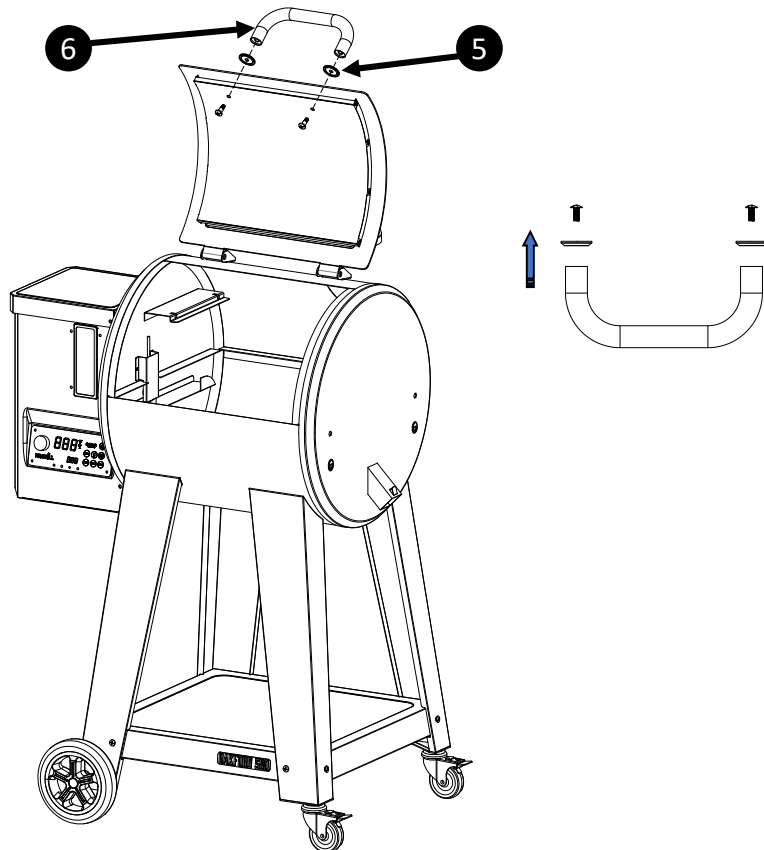

7

A×4 B×4 C×4

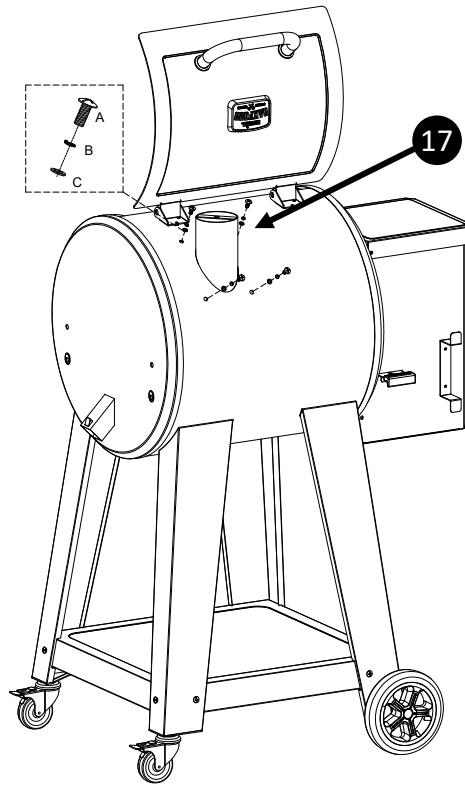

8

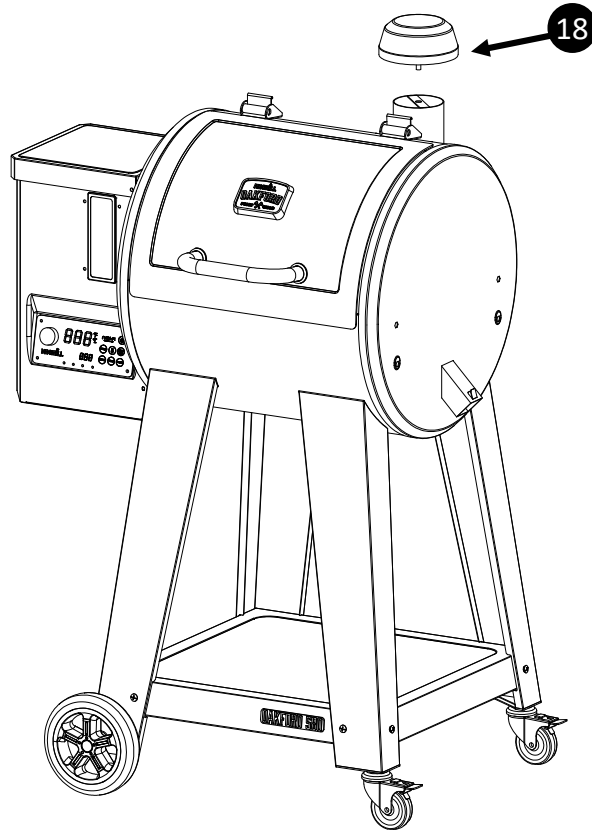

9

A×2 B×2 C×2

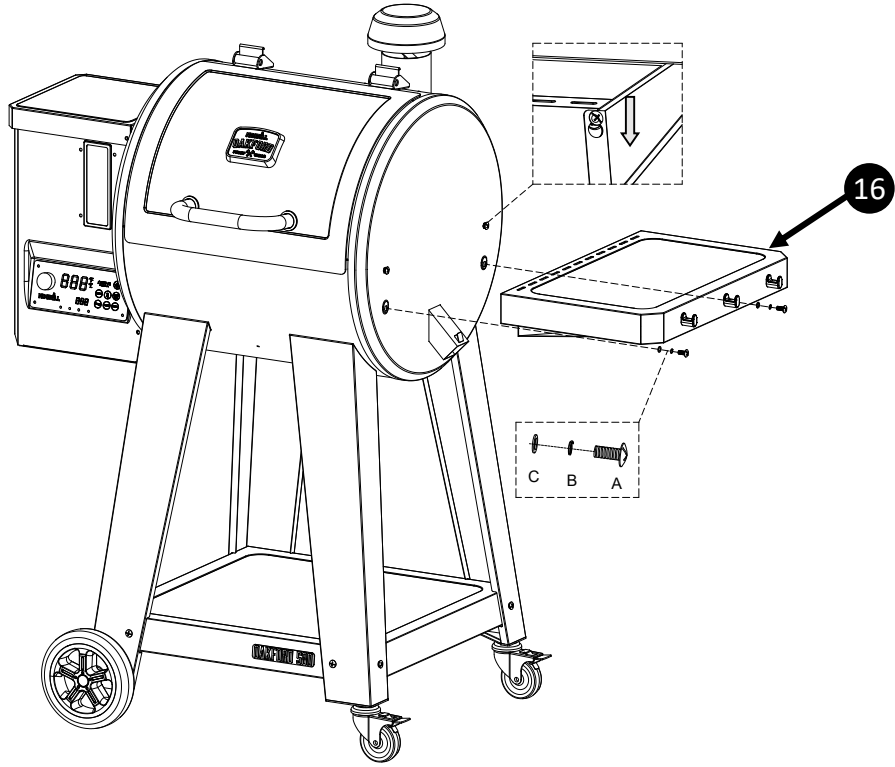

10

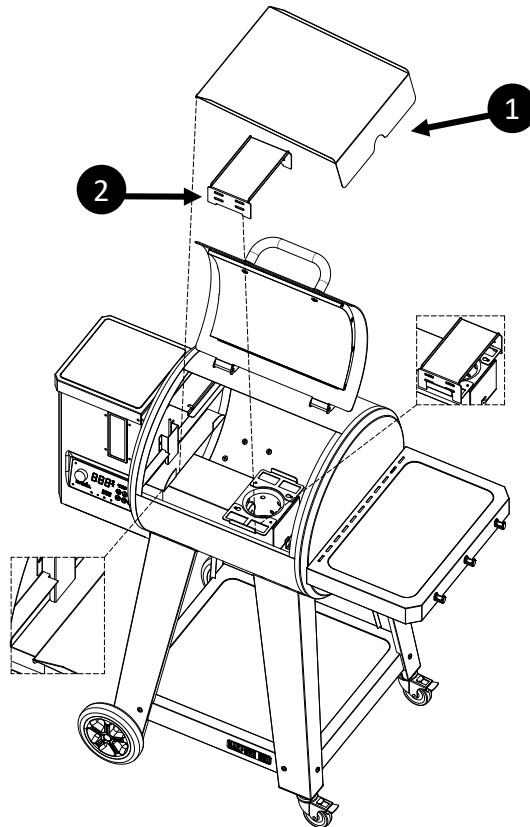

11

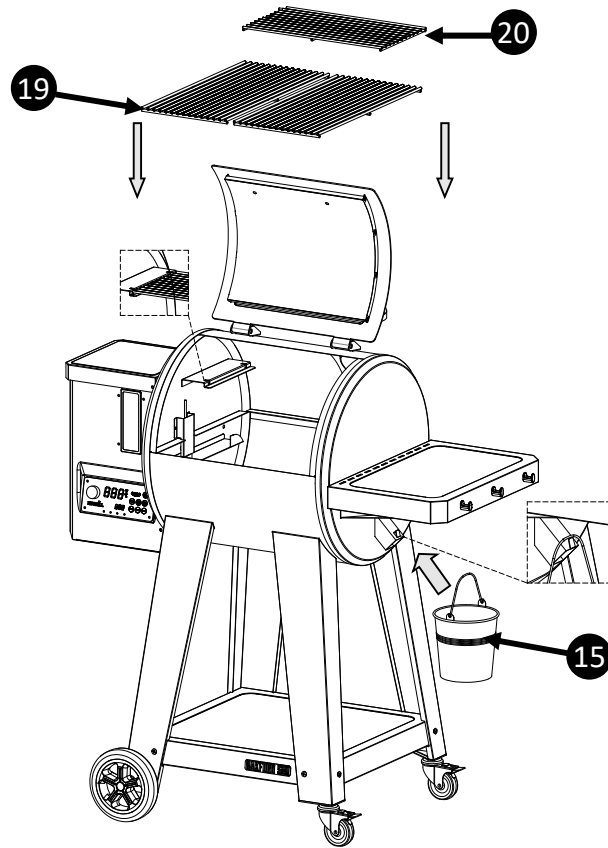

12

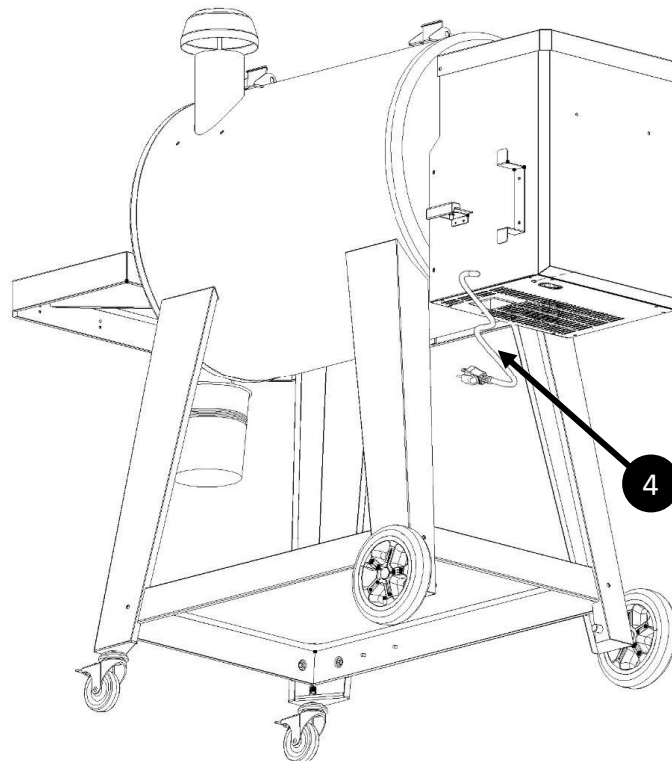

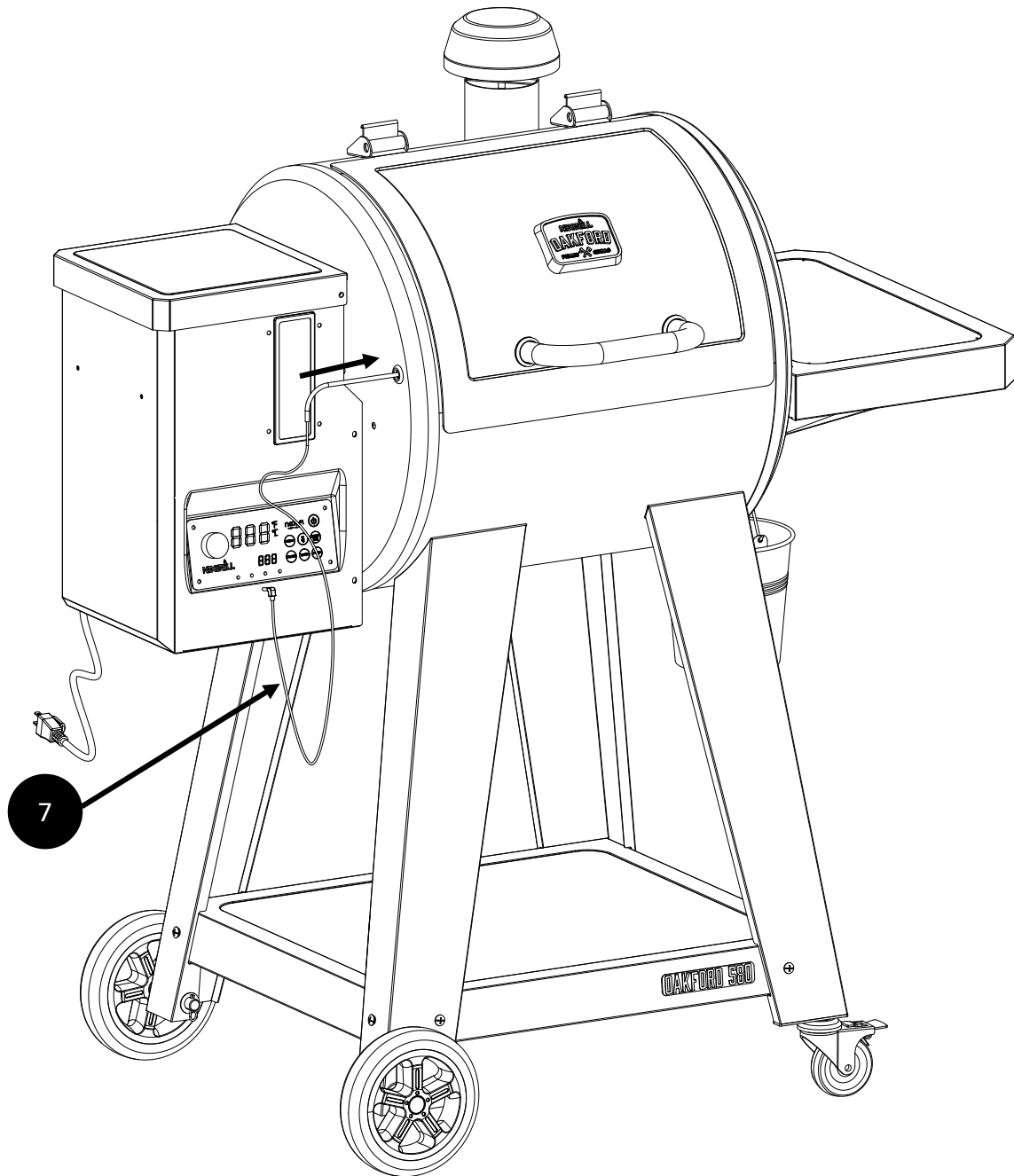

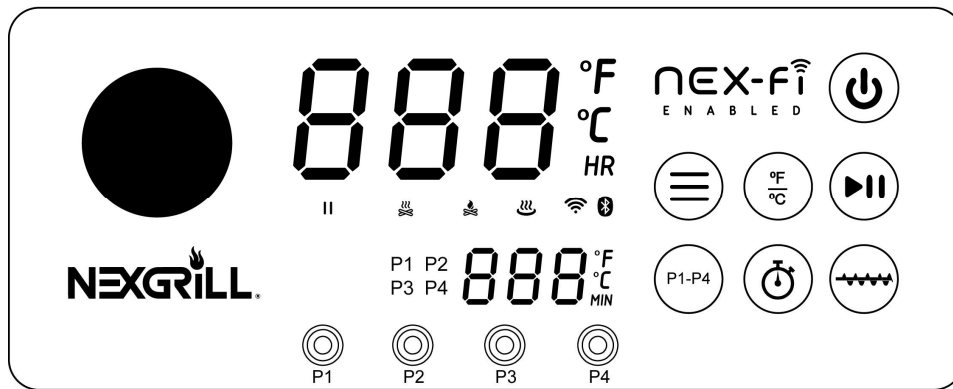

CONTROL DIAL

Turn this control dial to adjust the values for the timer, meat probe temperature, and grill temperature. Push the control dial to confirm new targeted value. The grill temperature can be adjusted in 5 °F (3 °C) increments. During cooking, push the knob to display the current grill set temperature.



POWER

Press to turn on the controller. When finished cooking, press again to enter the automatic shutdown process.



MODE

Press to cycle between the three preset operating modes. Press the control dial to confirm mode selection with default a temperature or adjust the temperature before selecting by rotating the control dial.

	<p>SMOKE MODE Pre-programmed for slow smoking, this program has a default temperature of 225°F (107 °C).</p>
	<p>GRILL MODE Using a PID algorithm for accurate temperature control, this program has a default temperature set to "HI" (above 550°F (288 °C) depending on model).</p>
	<p>WARM MODE Preset to only 180 °F (82 °C), this mode is specifically used to keep food warm. If selected, the grill will automatically switch to WARM when P1 has reached the target temperature.</p>



TEMPERATURE UNIT

Press to switch the temperature scale between Fahrenheit and Celsius.



PLAY/pause

Initially used to start the ignition process once a cooking mode is selected, this can be pressed while cooking to pause the program. It will help prevent auger overfeeding pellets due to a temperature decrease (e.g. lid open). When paused, or once it is powered on, the grill will be in standby and the "II" (pause) icon will illuminate.

Press it again to resume the last program. If no action is taken within five minutes, the grill will enter the shutdown process.



PROBES

This Oakford Pellet Grill can operate up to four temperature probes to help you cook a variety of foods to perfection. Press to cycle through each probe connected. Once the index is displayed (P1, P2, etc.), press and hold for three seconds to set the target temperature. Use the control dial to change the temperature value and press it to confirm the value.



TIMER

Press to set a timer in minutes and hours. The controller will alarm once the time has expired.

To set a timer:

1. Press the button. The lower number display will flash. Adjust the minute value using the control dial. Push the control dial to confirm.
2. Now, the upper number display will flash. Adjust the hour using the control dial. Push the control dial to confirm and start the timer.

The "HR" and "MIN" symbols will flash, indicating that the timer is running. Press the button to check remaining time. Press and hold the button for 3 seconds to cancel the timer.



PRIME

Press to run the auger for 30 seconds before or after cooking. If more time is needed to load or empty pellets from the auger tube, press the button again once it stops flashing. Press and hold for 3 seconds to cancel this action.

Operating Instruction

BEFORE FIRST USE

1. Remove all packaging materials from the grill.
2. The barbecue has to be installed on a secure level base prior to use.
3. Open the grill to make sure the warming rack, cooking grids, diffuser and grease tray are properly installed.
4. Open the hopper lid and verify there are no foreign objects obstructing the auger.
5. Make sure the hopper safety guard is in place and the pellet cleanout door is closed and locked.
6. Fill the hopper with your choice of pellets to your desired fuel level and close the hopper lid.
7. Make sure the power cord is connected to the grill before plugging the other end into a grounded electronic outlet.
8. Turn on your grill by pressing the power button on the controller.
9. Open the grill lid.
10. Prime the auger tube by pressing the PRIME button, which activates the auger for 30 seconds. Repeat this cycle until you hear pellets dropping into the fire pot. Press and hold PRIME for 3 seconds to stop it.
11. Using the control dial, set the temperature to 400 °F (204 °C) and press the dial to confirm.
12. Press PLAY/PAUSE to start the ignition process.
13. Once the grill has lit, close the grill lid. During ignition, there may be a large amount of smoke coming from the grill.
14. While monitoring the grill, the barbecue shall be heated up and the fuel kept red hot for at least 30 minutes prior to the first cooking. This will remove manufacturing process oils and help season the grill.
15. After the seasoning is done, press the power button to begin the automatic shutdown process.
16. Once the grill has been properly shut down and cooled, unplug the grill from the power source.
17. Open the lid and clean the cooking grates and warming racks with a grill brush or wood scraper.
18. Clean thoroughly following the instructions in "Care and Maintenance Instruction" section.
19. Once your grill is cleaned, make sure all parts are reinstalled properly before use.

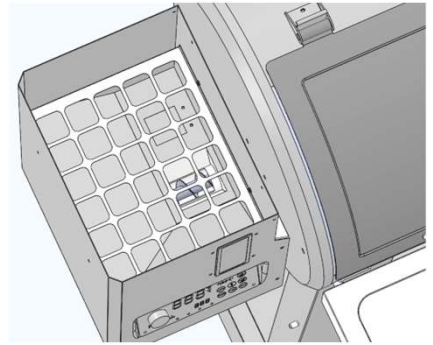
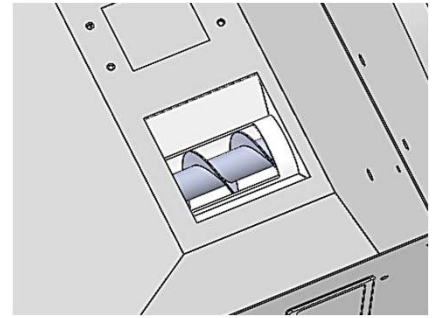

EACH AND EVERY USE

Follow the steps every time you operate your Oakford pellet grill:

1. Make sure the hopper is filled with enough pellets. Refer to the pellet fuel indicator on the hopper for recommended pellet quantity.
2. Clean and dispose of any residual ash and grease. Inspect for creosote buildup. Remove accumulated grease and creosote to reduce the risk of fire.
3. Always plug the power cord into a grounded outlet.
4. Open the grill lid while lighting.
5. Use the Nexgrill app to enhance your grilling experience.

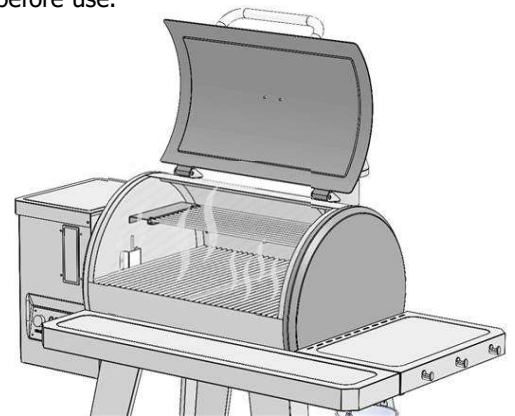

LIGHTING YOUR GRILL - AUTOMATICALLY

Make sure your grill is properly setup and ready for use.

1. Open the grill lid and verify all the components are in place.
2. Ensure the hopper does not contain foreign objects and is filled with enough barbecue pellets.
3. Be certain the auger is primed and ready for use. If not, review PRIME function for proper setup.
4. Plug the power cord into a properly grounded electrical outlet and press the POWER button.
5. Press PLAY/PAUSE, or first enter the desired cooking mode and temperature. If nothing was entered, the grill will start with a default target temperature of 360 °F (182 °C). Within 5 minutes smoke should be visible. If not, turn off the controller and wait 5 minutes before repeating.
6. Once the grill has lit, close the lid. Set the desired cooking mode and temperature if not already entered.
7. Do not cook before the fuel has a coating of ash.

TURNING OFF YOUR GRILL

When your cooking is done, your OAKFORD must be properly turned off to clear the fire pot of any remaining pellets and ashes. Use this procedure to properly turn off your grill after each use.

1. Open the lid, remove all meat probes and food.
2. With the lid still open, press the Power button to begin the automatic shutdown process. During this process, the fan will continue to run until the grill temperature falls below 130 °F (54 °C), at least 15 minutes, to assist with the burn off process. Do not unplug the grill until after the fan has completed this process and turned off.
3. Unplug the grill from the power source.
4. Wait until the grill has cooled down before storing it for your next cook out.

Operating Instruction

LIGHTING YOUR GRILL - MANUALLY

Make sure your grill is properly setup and ready for use.

1. Open the grill lid and remove the grids, grease tray and diffuser.
2. Ensure the hopper does not contain foreign objects and is filled with enough barbecue pellets.
3. Check that the fire pot is clean and does not contain any foreign objects.
4. Plug the power cord into a properly grounded electrical outlet.
5. The auger should be primed and ready for use. If not, review PRIME function for proper setup.
6. Add a handful of barbecue pellets to the fire pot.
7. Add a natural wood fire starter or gel to the fire pot.
8. With a long match or lighter, ignite the fire starter.
9. After the pellets are burning well, replace the diffuser, grease tray and grids.
10. Press the POWER button.
11. Press PLAY/PAUSE. Observe that more pellets have been added and are burning properly.
12. Once the grill has lit, close the lid.
13. Set the desired cooking mode and temperature if not already entered.

WARNING! Do not use spirit or petrol for lighting or re-lighting! Use only use firelighters complying to EN 1860-3!

CHANGING PELLETS

When you want to change the pellet flavor for your next gathering, or purge the hopper for a thorough maintenance, follow the instructions below:

1. Locate the opening on the bottom of pellet hopper and place a large container underneath.
2. From the back of your OAKFORD grill, loosen the lock screw on the pellet cleanout door by turning counterclockwise two full turns (A).
3. Pull out the pellet cleanout door to release the pellets into your container.
4. Once the hopper is empty, push the pellet cleanout door back in and lock it by rotating the lock screw clockwise (B).
5. Connect the grill to a grounded outlet and press the POWER button.
6. Press PRIME so the auger removes pellets from the auger screw into the fire pot. Repeat this until the auger is empty.
7. Using a vacuum, remove the pellets and ash from the fire pot.

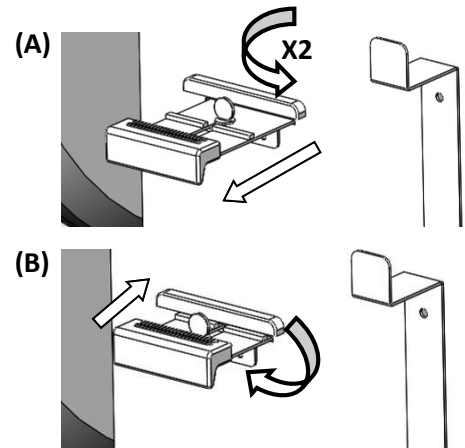

WARNING: Visually inspect the hopper finger safety guard to make sure that it is in place and not damaged before filling the hopper with your choice of pellets. DO NOT change pellets when the grill is hot.

USING TEMPERATURE PROBES

Use the provided meat probe to control your OAKFORD pellet grill by following the steps below:

1. Plug the meat probe into the port at the bottom of the controller*, then route the probe through the opening hole on the left side of the cooking chamber (C). Make sure to wear heat protective gloves.
2. Insert the temperature probe into the thickest part of your choice of meat.
3. Place your food on the cooking grate and close the grill lid.
4. Refer to Controller Feature page for instructions set targeted probe temperature.

***AUTO-WARM FEATURE:** With the meat probe connected to port P1, set the target temperature desired for the food to activate the auto-warm feature. This feature will automatically reduce the set grill temperature to 180 °F (82 °C) and display the WARM icon after the probe temperature hits its targeted temperature. The grill will maintain at WARM setting (for a maximum of 10 minutes) as it awaits the next user input. This is to help prevent food from overcooking if the user is not present when the set meat probe temperature has been reached. To avoid this auto warm feature, please use ports P2 to P4 instead. Alternatively, you can turn off this feature through the "NEX-Fi" APP.

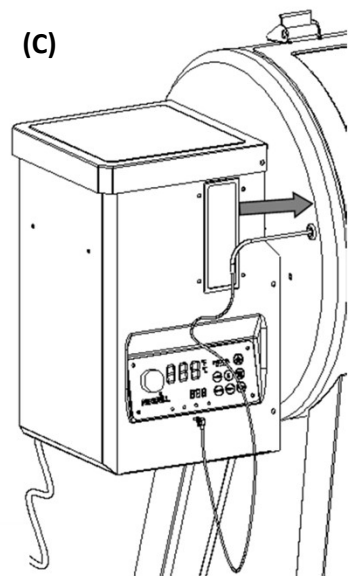

CARE AND MAINTENANCE INSTRUCTIONS



CAUTION!
MAKE SURE THAT THE GRILL IS COOLED AND PLUG UNPLUGGED FROM THE POWER SOURCE BEFORE PERFORMING ANY CLEANING OR MAINTENANCE.

Interior

COOKING GRATES

- After the grill has cooled, scrub both sides of the cooking grates with a wire-bristled grill brush.
- Any stubborn, baked-on food residue can be scraped off with a scraper.
- Grates can also be removed from the grill and washed with dish soap and warm water. Dry thoroughly.
- The cooking grates should be cleaned after each use.

GREASE SYSTEM

- Remove the cooking grids and scrape food and grease residue off the grease tray using a scraper or grill brush.
- Grease tray can also be removed from the grill and washed with dish soap and warm water. Dry thoroughly.
- Grease cup can be lined with foil grease cup liners for easy clean-up.
- The grease tray should be cleaned after each use. The grease cup should be emptied once it reaches $\frac{3}{4}$ full.

INTERIOR SURFACES

- Brush or scrape off any grease or debris accumulated on the interior surfaces using a scraper or grill brush.
- Vacuum ash and food remnants out of the bottom of the firebox and firepot.
- All surfaces can be washed with mild, soapy water and/or a mild degreaser. Dry thoroughly.
- Interior surfaces should be monitored and cleaned when build-up of grease and debris has accumulated, but not less than twice per year.

EXTERIOR

COATED AND PLASTIC SURFACES

- After the grill has cooled completely, exterior surfaces can be wiped down with a mild mixture of soap and water. Dry thoroughly.
- Do not use abrasive cleaners.

STAINLESS STEEL (APPLICABLE ON SOME MODELS)

- Use a stainless-steel cleaner and non-abrasive, lint-free cloth to clean stainless steel components.
- Always rub in the direction of the grain to avoid scratches and do not use paper towels.

DO NOT SPRAY THE GRILL WITH A GARDEN HOSE OR POWER WASHER TO PREVENT DAMAGE TO ELECTRICAL COMPONENTS.

STORAGE

- Always store your grill with a cover between uses to prevent corrosion or other damage to the grill, especially if it is stored in a rainy or humid environment.
- Do not store the grill with the hopper and/or auger full of pellets, especially in wet or humid conditions. Moisture will expand the pellets and can lead to an auger jam. Use the pellet quick release door located at the back of the hopper to empty leftover pellets into a container and burn off any pellets remaining in the auger before storage.
- Store spare wood pellets in an airtight container, away from heat-producing appliances, moisture, and other fuel containers. Before use, check the freshness of your pellets by breaking one in half. The pellet should break with a snap. If it crumbles, that means your pellet is not fresh and will impact the performance of the grill.



- **Creosote – Formation and need for removal.** When wood pellets are burned slowly, they produce tar and other organic vapors that combine with expelled moisture to form creosote. The creosote vapors condense in a relatively cool oven flue and exhaust hood of a slow burning fire. As a result, creosote residue accumulates on the flue lining and exhaust hood. When ignited, this creosote makes an extremely hot fire.
- The grease duct should be inspected at least twice a year to determine when grease and/or creosote build up has occurred.
- When grease or creosote has accumulated, it should be removed to reduce risk of fire.

ERROR CODES

On a rare occasion, your controller would detect an issue and you may see an error code displayed on the controller. Please refer to the following table for descriptions and solutions:

ERROR CODE	ERROR DESCRIPTION	SOLUTION
ER1	Firebox thermocouple sensor failure	This error will occur when the thermocouple has lost connection to the controller due to a loose wire connection or failure of the thermocouple, which will require a replacement.
ER2	Ignition failure	This error will occur when the grill fails to detect a temperature increase within 15 minutes of temperature set, indicating a failure to ignite. Ambient temperature, clogged auger tube, lack of pellets, ash build-up, etc. can impact ignition. Check the pellet feed system and restart the grill.
ER3	High Temperature Limit Failure	This error will occur when the grill temperature exceeds 675 °F (357 °C). Let the grill cool down, then turn off the grill. Restart the grill after clearing out the remaining pellets from the firebox.
ER4	Low Temperature Limit Failure	If the grill temperature falls too far below the set temperature, this code will appear. This can happen when grilling with the lid open. In that case, the user can clear the error code by pushing the control dial. If not cooking with the lid open, it may indicate that the igniter has gone out. In that case the user should shut down the grill and empty out the burn pot before restarting.
ER5	Probe Communication Failure	This error will occur if a temperature probe plugged into port P1 that has a set target temperature loses connection. Verify that the meat probe is properly connected to the controller. If problem persists, the probe will need to be replaced.
ER9	Network Communication Failure	If the controller was previously connected to the Wi-Fi network, this error indicates that the internet is not working and/or the connection to the Wi-Fi network has been disconnected. Restart your grill, make sure where you grill has a strong Wi-Fi signal.

NOTE: To dismiss an error code, push the control dial.

GIVE US A

CALL

For replacement parts, please call our customer service department at: (03) 9702 8823, 8 a.m. - 5 p.m., Monday-Friday.



IMPORTANT:

Use only factory authorized parts. The use of any part that is not factory authorized can be dangerous. This will also void your warranty.

TROUBLESHOOTING

FREQUENTLY ASKED QUESTIONS

QUESTION	ANSWER
What do I do if the auger jams?	<ol style="list-style-type: none"> 1. Unplug the grill and wait for it to cool down. 2. If the jam cannot be broken up from the pellet hopper opening, the auger and motor may need to be removed. 3. Contact customer service for help with removing the auger to clear it.
Why is the temperature of my pellet grill fluctuating?	Temperature fluctuations are normal. Any significant fluctuation could be the result of wind and ambient temperature, pellet quantity, or lack of maintenance. Avoid using the pellet grill when it is windy or raining outside.
Why is the fire not remaining lit?	Excess ash in the burn pot can cause this by covering the igniter and preventing the pellets from burning. Unplug the grill and wait for it to cool down, then remove the cooking grids, grease tray, and heat diffuser. Remove any pellets and ash from the burn pot. A vacuum with a hose attachment is ideal to remove ashes from the burn pot.
Why is the grill not heating to the set temperature?	This is typically due to the burn pot not getting enough oxygen to achieve the desired temperature. Inspect the burn pot and make sure it does not contain too much ash. Check the hopper and add more pellet if necessary. Replace them if they are damp. You should also check the fan to make sure it is working.
How do I avoid flare-up?	If you are cooking food that contain a lot of fat/grease, keep the temperature at or below 350 °F (177 °C) to avoid flare-up.

HOW TO ORDER REPLACEMENT PARTS

To make sure you obtain the correct replacement part(s) for your grill, please refer to the replacement parts list. Keep this assembly and operating instruction manual for convenient referral, and for replacement parts ordering.

THE FOLLOWING INFORMATION IS REQUIRED TO ENSURE THE CORRECT PART IS ORDERED:

- Oakford™ pellet grill model number
- Serial number
- Part number
- Description
- Quantity

TO OBTAIN REPLACEMENT PARTS, PLEASE CONTACT OUR CUSTOMER SERVICE HOTLINE

(03) 9702 8823, 8 a.m.-5 p.m., Monday-Friday.

Electrical circuit diagram

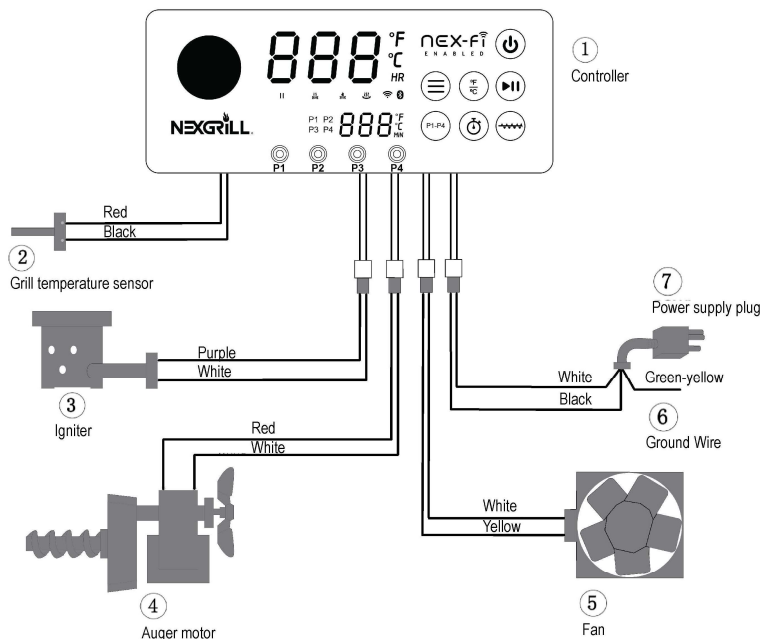

Limited Warranty

The manufacturer warrants to the original consumer-purchaser **ONLY** that this product (*Model # 910-05001AU*) shall be free from defects in workmanship and materials after correct assembly and under normal and reasonable home use for the periods indicated below beginning on the date of purchase. The manufacturer reserves the right to require photographic evidence of damage, or that defective parts be returned, postage and/or freight pre-paid by the consumer, for review and examination. Nexgrill's obligation is limited to repair, replacement, or depreciated value, at the option of Nexgrill.

All Pellet Grill Models	WARRANTIES
Firebox and all components not covered below	5 years
Electrical Components	3 years
Cooking grates	3 years

Upon consumer supplying proof of purchase as provided herein, Manufacturer will repair or replace the parts which are proven defective during the applicable warranty period. Parts required to complete such repair or replacement shall be free of charge to you except for shipping costs, as long as the purchaser is within the warranty period from the original date of purchase. The original consumer-purchaser will be responsible for all shipping charges of parts replaced under the terms of this limited warranty. This limited warranty is applicable in the Australia only, is only available to the original owner of the product and is *not transferable*. Manufacturer requires reasonable proof of your date of purchase. Therefore, you should retain your sales receipt and/or invoice. If the unit was received as a gift, please ask the gift-giver to send in the receipt on your behalf, to the below address. Defective or missing parts subject to this limited warranty will not be replaced without registration or proof of purchase. **This limited warranty applies to the functionality of the product ONLY and does not cover cosmetic issues such as scratches, dents, corruptions or discoloring by heat, abrasive and chemical cleaners or any tools used in the assembly or installation of the appliance, surface rust, or the discoloration of stainless-steel surfaces. Surface rust, corrosion, or powder paint chipping on metal parts that does not affect the structural integrity of the product is not considered a defect in workmanship or material and is not covered by this warranty.** This limited warranty will not reimburse you for the cost of any inconvenience, food, personal injury or property damage. If an original replacement part is not available, a comparable replacement part will be sent. You will be responsible for all shipping charges of parts replaced under the terms of this limited warranty.

MANUFACTURER WILL NOT PAY FOR:

- Service calls to your home.
- Repairs when your product is used for other than normal, single-family household or residential use.
- Damage resulting from accident, alteration, misuse, lack of maintenance/cleaning, abuse, fire, flood, acts of God, improper installation, and installation not in accordance with electrical or plumbing codes or misuse of product.
- Any food loss due to product failures.
- Replacement parts or repair labor costs for units operated outside Australia.
- Pickup and delivery of your product.
- Postage fees or photo processing fees for photos sent in as documentation.
- Repairs to parts or systems resulting from unauthorized modifications made to the product.
- The removal and/or reinstallation of your product.
- Shipping cost, standard or expedited, for warranty/non warranty and replacement parts.

DISCLAIMER OF IMPLIED WARRANTIES; LIMITATION OF REMEDIES

Repair or replacement of defective parts is your exclusive remedy under the terms of this limited warranty. Manufacturer will not be responsible for any consequential or incidental damages arising from the breach of either this limited warranty or any applicable implied warranty, or for failure or damage resulting from acts of God, improper care and maintenance, grease fire, accident, alteration, replacement of parts by anyone other than manufacturer, misuse, transportation, commercial use, abuse, hostile environments (inclement weather, acts of nature, animal tampering), improper installation or installation not in accordance with local codes or printed manufacturer instructions.

THIS LIMITED WARRANTY IS THE SOLE EXPRESS WARRANTY GIVEN BY THE MANUFACTURER. NO PRODUCT PERFORMANCE SPECIFICATION OR DESCRIPTION WHEREVER APPEARING IS WARRANTED BY MANUFACTURER EXCEPT TO THE EXTENT SET FORTH IN THIS LIMITED WARRANTY. ANY IMPLIED WARRANTY PROTECTION ARISING UNDER THE LAWS OF ANY STATE, INCLUDING IMPLIED WARRANTY OF MERCHANTABILITY OR FITNESS FOR A PARTICULAR PURPOSE OR USE, IS HEREBY LIMITED IN DURATION TO THE DURATION OF THIS LIMITED WARRANTY.

Neither dealers nor the retail establishment selling this product has any authority to make any additional warranties or to promise remedies in addition to or inconsistent with those stated above. Manufacturer's maximum liability, in any event, shall not exceed the documented purchase price of the product paid by the original consumer. This warranty only applies to units purchased from an authorized retailer and or re-seller. NOTE: Some states do not allow an exclusion or limitation of incidental or consequential damages, so some of the above limitations or exclusions may not apply to you; this limited warranty gives you specific legal rights as set for herein. You may also have other rights which vary from state to state.

If you wish to obtain performance of any obligation under this limited warranty, you should write to:
HARK Enterprises Pty Ltd
19 - 25 Cyber Loop
Dandenong South. VIC. 3175
All consumer returns, parts orders, general questions, and troubleshooting assistance can be acquired by calling (03) 9702 8823, 8 a.m.-5 p.m., GMT+8. Monday-Friday.

Replacement Parts

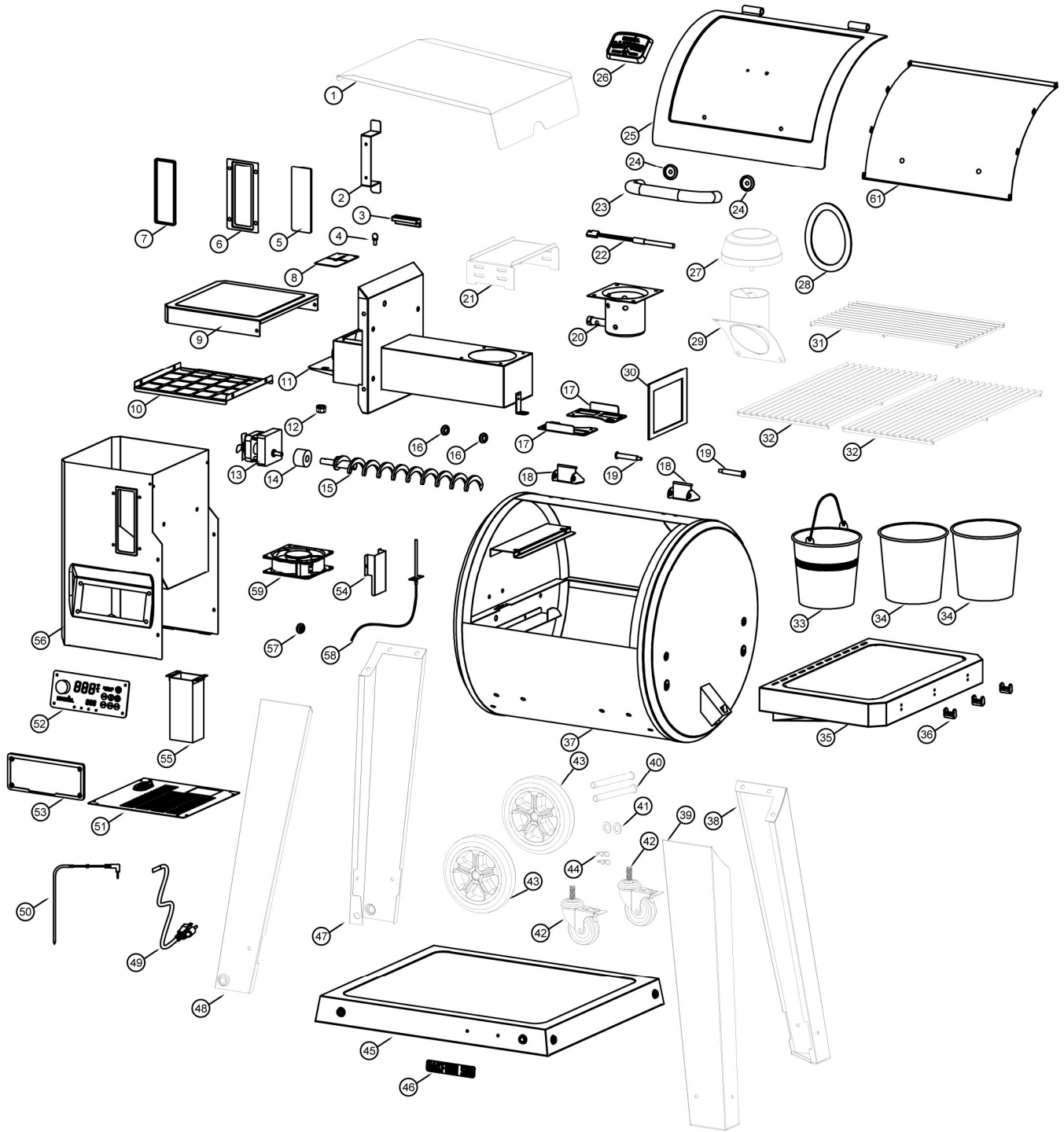

Replacement Parts

NO.	PART (DESCRIPTION)	WARRANTY COVERAGE	QTY	NO.	PART (DESCRIPTION)	WARRANTY COVERAGE	QTY
1	Grease Tray	5	1	33	Grease Bucket	5	1
2	Power Cord Bracket	5	1	34	Grease Bucket Liner	5	2
3	Drop Chute Plate Handle	5	1	35	Side Shelf	5	1
4	Drop Chute Plate Screw	5	1	36	Hook	5	3
5	Glass Window	5	1	37	Firebox	5	1
6	Glass Window Bracket	5	1	38	Cart Leg, Rear Right	5	1
7	Glass Window Seal	5	1	39	Cart Leg, Front Right	5	1
8	Pellet Cleanout Door	5	1	40	Wheel Axle	5	2
9	Hopper Lid	5	1	41	Wheel Washer	5	2
10	Hopper Safety Screen	5	1	42	Locking Caster	5	2
11	Auger Housing	5	1	43	7" Wheel	5	2
12	Power Cord Fastener	5	1	44	Wheel Cotter Pin	5	2
13	Auger Motor	3	1	45	Bottom Panel	5	1
14	Nylon Bushing	5	1	46	Name Plate (on Bottom Panel)	5	1
15	Auger	3	1	47	Cart Leg, Rear Left	5	1
16	Silicone Ring A (for Motor Wire/Ignition Rod Cable Hole)	5	2	48	Car Leg, Front Left	5	1
17	Heat Diffuser Bracket	5	2	49	Power Cord	3	1
18	Lid Hinge	5	2	50	Meat Probe	3	1
19	Lid Pin	5	2	51	Hopper Bottom Panel	5	1
20	Burn Pot	5	1	52	Controller	3	1
21	Heat Diffuser	5	1	53	Controller Fascia	5	1
22	Ignition Rod	5	1	54	RTD Cover	5	1
23	Lid Handle	5	1	55	Pellet Chute	5	1
24	Lid Handle Bezel	5	2	56	Hopper	5	1
25	Main Lid	5	1	57	Silicone Ring B (for Meat Probe Hole)	5	1
26	Name Plate (on Lid)	5	1	58	RTD	3	1
27	Chimney Cap	5	1	59	Fan	3	1
28	Chimney Gasket	5	1	61	Lid Heat Shield	5	1
29	Chimney	5	1				
30	Hopper Housing Gasket	5	1				
31	Warming Rack	3	1				
32	Cooking Grid	3	2				

THIS PAGE INTENTIONALLY LEFT BLANK

THIS PAGE INTENTIONALLY LEFT BLANK

THIS PAGE INTENTIONALLY LEFT BLANK

NEXGRILL

OAKFORD

PELLET  GRILLS

©2023 NEXGRILL INDUSTRIES, INC.
NEXGRILLBBQ.COM.AU